

Sealed combustion chamber gas fired storage water heater

SECURITY SX120



Product details



ErP Ready



Low Emissions



Wall Hanging

ATI DI MARIANI SRL SX120

Energy efficiency class: **B**

Sound power level: 45 dB

Energy consumption: 0015 kWh/annum, 13 GJ/annum

2017 812/2013



Code **SX120**
Price **€ 1.975,00**

Main characteristics

- Device operating with ATI original flue kits only
- Internal glazing
- Closed-cell polyurethane foam insulation
- Electronic ignition
- Corrosion protection with magnesium anode
- Adjustable thermostat and overheat safety thermostat
- Stainless steel multigas premix burner, natural gas ready
- LPG conversion kit included
- Adjustable flue hood
- Inspection and cleaning flange
- Various ATI flue kits available

Technical data		
Storage capacity	L	115
Nominal input (gross)	kW	5,00
Nominal output (net)	kW	4,30
Warm up time ($\Delta T = 45^{\circ}\text{C}$)	min	84
Continuous water at 40°C	l/h	148
Draw-off capacity single withdrawal*	L	230
Methane consumption (G20)**	m ³ /h	0,52
Propane consumption (G31)**	kg/h	0,39
Max operating pressure	bar	6
Net weight	kg	56
Connections		
Cold Water Inlet	F	G 1/2" M
Hot Water Outlet	C	G 1/2" M
Recirculation	R	/
Gas Inlet	G	G 3/8"
Exhaust fumes - concentric	S	ø38/60
Exhaust fumes - split		ø38 ø60
Packaging		
Packages	n.	1
Wooden cage (l x w x h) - (weight)	cm - (kg)	/
Box (l x w x h) - (weight)	cm - (kg)	53x53x150 - (63)

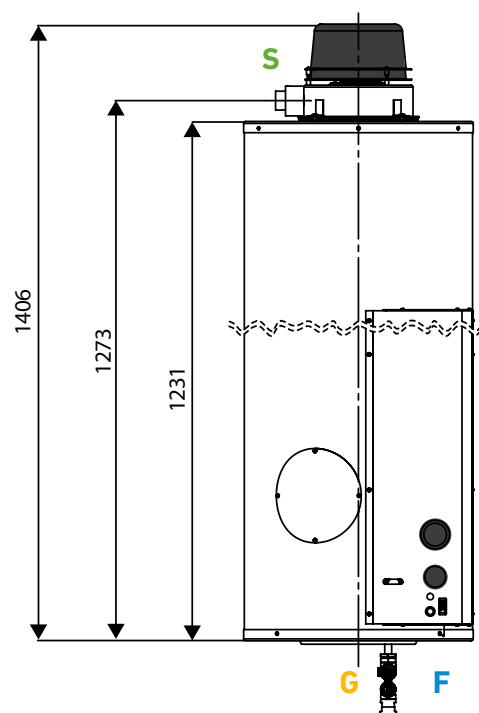
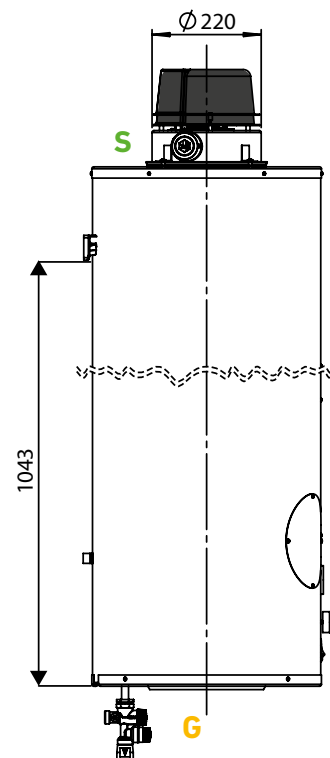

*Under standard conditions: T in 15°C , T out 40°C , T storage 65°C

** Under standard conditions: T in 15°C , 1013 mbar

