

Sealed combustion chamber gas fired storage water heater

# SECURITY SX220

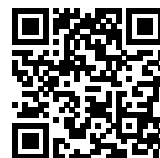

Product details



ErP Ready



Low Emissions

**Methane**

Code **SX220**

Price € **3.675,00**

**Propane**

Code **SX220P**

Price € **3.695,00**



Exhaust kit from page. 54

ENERG Y UA IE IA

ATI DI MARIANI SRL SX220

XXL

A+ A B C D E F

B

51 dB

0014 28 kWh/annum GJ/annum

2017 812/2013

### Main characteristics

- Device operating with ATI original flue kits only
- Internal glazing
- Closed-cell polyurethane foam insulation
- Electronic ignition
- Corrosion protection with magnesium anode
- Adjustable thermostat and overheat safety thermostat
- Stainless steel multigas burner, natural gas or propane ready
- Flue safety pressure switch
- Overpressure safety valve
- Inspection and cleaning flange
- Various ATI flue kits available

Technical data		
Storage capacity	L	220
Nominal input (gross)	kW	22,00
Nominal output (net)	kW	20,02
Warm up time ( $\Delta T = 45^{\circ}\text{C}$ )	min	35
Continuous water at $40^{\circ}\text{C}$	l/h	689
Draw-off capacity single withdrawal*	L	440
Methane consumption (G20)**	m <sup>3</sup> /h	2,30
Propane consumption (G31)**	kg/h	1,70
Max operating pressure	bar	6
Net weight	kg	175
Connections		
Cold Water Inlet	F	G 1" 1/4
Hot Water Outlet	C	G 1" 1/4
Recirculation	R	G 1" 1/4
Gas Inlet	G	G 1/2"
Exhaust fumes - concentric	S	$\varnothing 60/100, \varnothing 80/125$
Exhaust fumes - split		$\varnothing 80 \varnothing 80$
Packaging		
Packages	n.	2
Wooden cage (l x w x h) - (weight)	cm - (kg)	78x78x140 - (183)
Box (l x w x h) - (weight)	cm - (kg)	67x67x26 - (9)

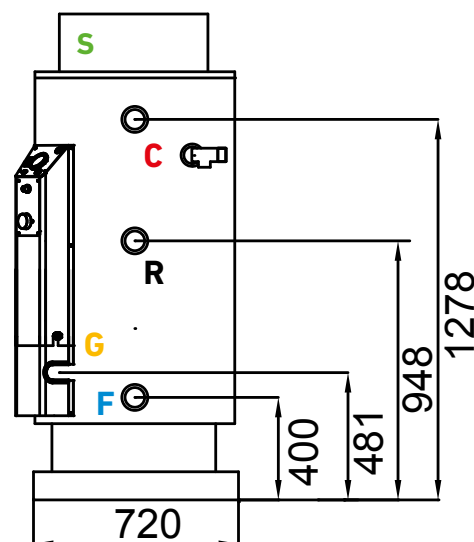
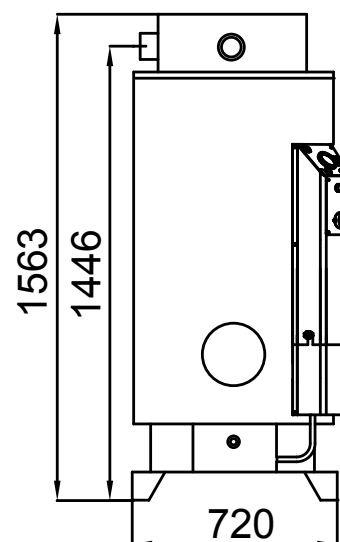

\*Under standard conditions: T in  $15^{\circ}\text{C}$ , T out  $40^{\circ}\text{C}$ , T storage  $65^{\circ}\text{C}$

\*\* Under standard conditions: T in  $15^{\circ}\text{C}$ , 1013 mbar