

Sealed combustion chamber gas fired storage water heater

SECURITY SX400

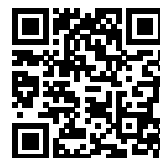

Product details



ErP Ready



Low Emissions

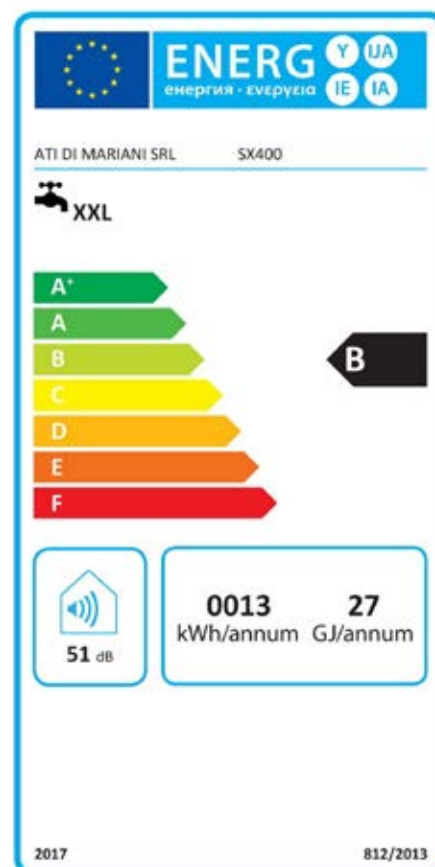

Methane

Code **SX400**

Price € **4.680,00**

Propane

Code **SX400P**

Price € **4.695,00**



Main characteristics

- Device operating with ATI original flue kits only
- Internal glazing
- Closed-cell polyurethane foam insulation
- Electronic ignition
- Corrosion protection with magnesium anode
- Adjustable thermostat and overheat safety thermostat
- Stainless steel multigas burner, natural gas or propane ready
- Flue safety pressure switch
- Overpressure safety valve
- Inspection and cleaning flange
- Various ATI flue kits available

Technical data		
Storage capacity	L	400
Nominal input (gross)	kW	23,00
Nominal output (net)	kW	21,05
Warm up time ($\Delta T = 45^{\circ}\text{C}$)	min	60
Continuous water at 40°C	l/h	724
Draw-off capacity single withdrawal*	L	800
Methane consumption (G20)**	m ³ /h	2,40
Propane consumption (G31)**	kg/h	1,80
Max operating pressure	bar	6
Net weight	kg	245
Connections		
Cold Water Inlet	F	G 1" 1/4
Hot Water Outlet	C	G 1" 1/4
Recirculation	R	G 1" 1/4
Gas Inlet	G	G 1/2"
Exhaust fumes - concentric	S	$\varnothing 60/100, \varnothing 80/125$
Exhaust fumes - split		$\varnothing 80 \varnothing 80$
Packaging		
Packages	n.	2
Wooden cage (l x w x h) - (weight)	cm - (kg)	78x78x211 - (263)
Box (l x w x h) - (weight)	cm - (kg)	67x67x26 - (9)

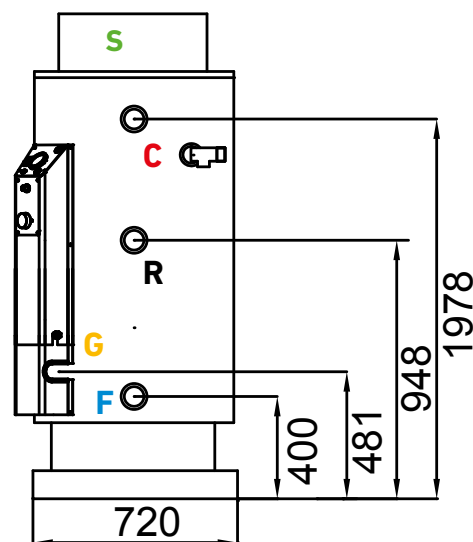
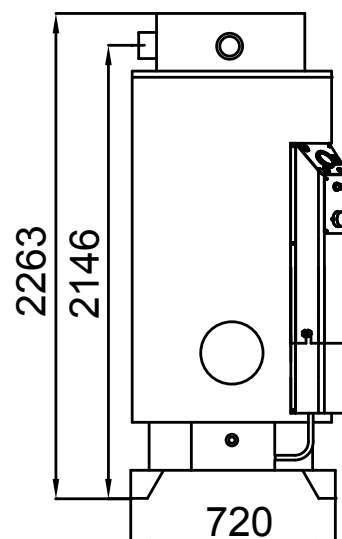

*Under standard conditions: T in 15°C , T out 40°C , T storage 65°C

** Under standard conditions: T in 15°C , 1013 mbar