

Natural flue draft gas fired storage water heater



Product details

TX220



ErP Ready



Low Emissions

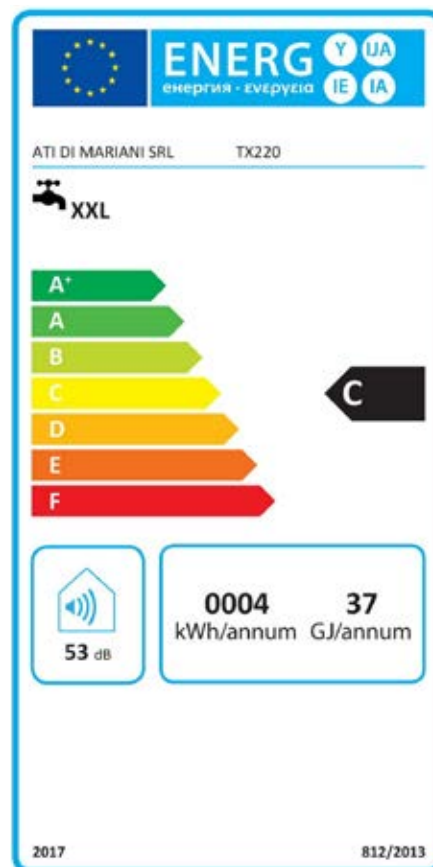

Methane

Code **TX220**

Price **€ 3.000,00**

Propane

Code **TX220P**

Price **€ 3.020,00**

Main characteristics

- Internal glazing
- Closed-cell polyurethane foam insulation
- Electronic ignition
- Corrosion protection with magnesium anode
- Adjustable thermostat and overheat safety thermostat
- Stainless steel multigas burner, natural gas or propane ready
- Flue gas safety thermostat
- Overpressure safety valve
- Inspection and cleaning flange

Technical data		
Storage capacity	L	220
Nominal input (gross)	kW	23,00
Nominal output (net)	kW	19,78
Warm up time ($\Delta T = 45^{\circ}\text{C}$)	min	35
Continuous water at 40°C	l/h	680
Draw-off capacity single withdrawal*	L	440
Methane consumption (G20)**	m ³ /h	2,40
Propane consumption (G31)**	kg/h	1,80
Max operating pressure	bar	6
Net weight	kg	173
Connections		
Cold Water Inlet	F	G 1" 1/4
Hot Water Outlet	C	G 1" 1/4
Recirculation	R	G 1" 1/4
Gas Inlet	G	G 1/2"
Exhaust fumes - concentric	S	/
Exhaust fumes - split		ø186
Packaging		
Packages	n.	2
Wooden cage (l x w x h) - (weight)	cm - (kg)	78x78x141 - (184)
Box (l x w x h) - (weight)	cm - (kg)	68x68x250 - (6)

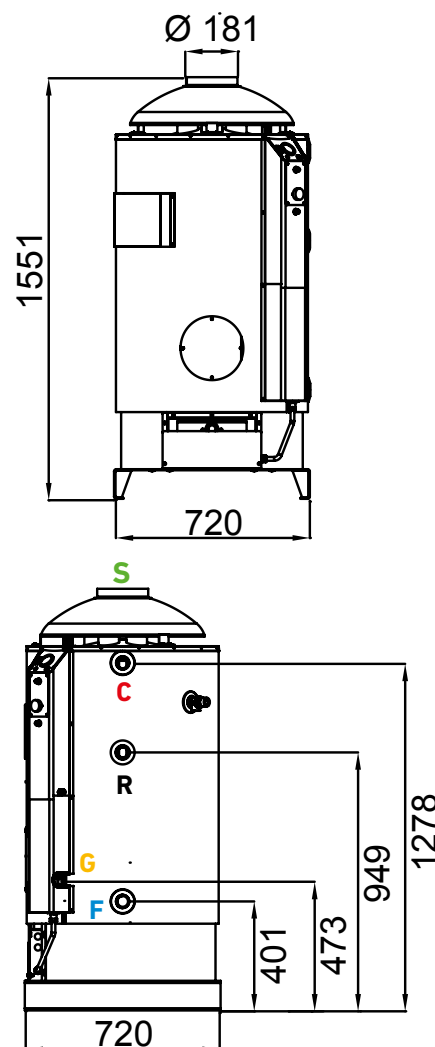

*Under standard conditions: T in 15°C , T out 40°C , T storage 65°C

** Under standard conditions: T in 15°C , 1013 mbar