

Condensing gas fired storage water heater

HYDRODENS



Product details



Video



ErP Ready



Low Emissions



Premix Burner

ATI DI MARIANI SRL HY49-350	
<p>62.9 dB</p>	<p>25 21</p> <p>kWh/annum GJ/annum</p>
<p>2017</p>	<p>812/2013</p>



Code **HY49-350**
 Price **€ 7.100,00**

Main characteristics

- Internal glazing
- Closed-cell polyurethane foam insulation
- Electronic ignition
- Impressed current cathodic protective system
- Natural gas up to 20% hydrogen approved
- Low NOx emissions premix burner (<40 mg/kwh)
- Weekly programming
- Anti-legionella function
- Antifreeze function
- Inspection and cleaning flange
- Various ATI flue kits available

Technical data		
Storage capacity	L	330
Nominal input (gross)	kW	49,90
Nominal output (net)	kW	50,65
Warm up time ($\Delta T = 45^{\circ}\text{C}$)	min	20
Continuous water at 40°C	l/h	1742
Draw-off capacity single withdrawal*	L	660
Methane consumption (G20)**	m ³ /h	5,43
Propane consumption (G31)**	kg/h	/
Max operating pressure	bar	6
Net weight	kg	202
Connections		
Cold Water Inlet	F	G 1" 1/4
Hot Water Outlet	C	G 1" 1/4
Recirculation	R	G 1" 1/4
Gas Inlet	G	G 3/4"
Exhaust fumes - concentric	S	$\varnothing 100/150$
Exhaust fumes - split		$\varnothing 100 \varnothing 100$
Packaging		
Packages	n.	1
Wooden cage (l x w x h) - (weight)	cm - (kg)	76x76x197 - (268)
Box (l x w x h) - (weight)	cm - (kg)	/

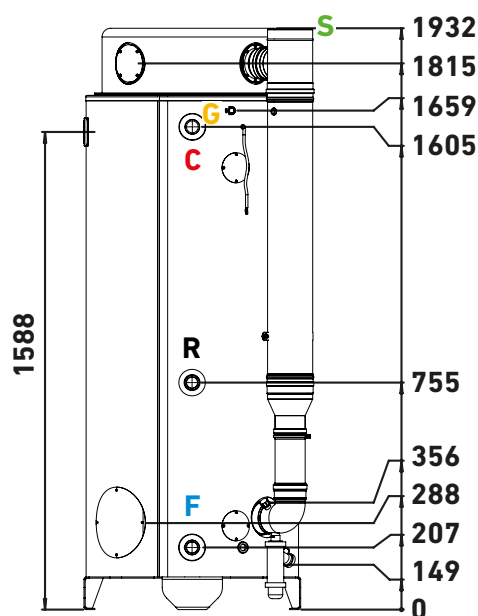
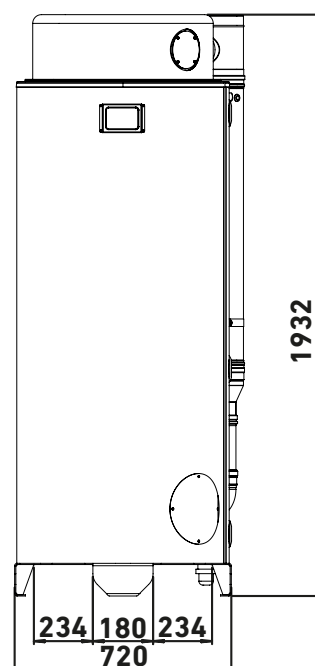

*Under standard conditions: T in 15°C , T out 40°C , T storage 65°C

** Under standard conditions: T in 15°C , 1013 mbar